

About the product

MegaSonic Model 2A-B & 2A-F Series Flush Doors are designed to limit the transmission of sound, or objectionable noise, from outside of the room. The two methods of rating are known as Sound Transmission Class (STC) and Sound Transmission Loss (STL).

MegaSonic Model 2A-B & 2A-F proprietary assemblies were tested as “operable” units in accordance with ASTM E-90 and achieved a STC-52 (Single Door Opening) & STC-50 Double Door Opening) rating. This was done using the rating system established in ASTM E-413. An extensive variety of door, frame & gasket combinations were tested in order to maximize choices in performance level. The sealed test was conducted solely to determine the door’s performance when not supplied as an assembly.

The MegaSonic Model 2A-B & 2A-F Sound Controlled Assembly consist of the door, frame, threshold & gasket. Locks, hinges & closer are supplied by the client. Hardware recommendations are contained in SDI-128 and HMMA 865 “Guide Specifications for Sound Control Hollow Metal Doors & Frames”.

MegaSonic Model 2A-B & 2A-F Series Doors are 1-3/4” (45mm) thick.

High gloss paint accentuates the visibility of all welds

THE USE OF HIGH GLOSS PAINT IS NOT RECOMMENDED.

Installation

1. Installation shall conform to the published MegaMet’s installation instructions and installation video posted on our website www.megametusa.com.

2. Fire Rated Assemblies must be in accordance with NFPA Pamphlet 80. The Authority Having Jurisdiction is the final authority on issues related to the installation and use of installed Fire Rated Doors.

Features and Benefits

MegaSonic Model 2A-B & 2A-F Series Doors offer the following standard unique features to provide long term performance and durability:

1. **Handicap Accessibility:** MegaSonic assemblies may be supplied with a low profile aluminum threshold that meets the requirements of the ADA Standard for accessible design and ICC/ANSI A117.1
2. **Cam-Lift Hinges not required:** MegaMet recommends the use of 5” heavy weight hinges (0.190”) furnished by the hardware supplier on all MegaSonic Model 2A assemblies. **Cam-Lift Hinges are not used.**
3. **Full perimeter 14-gauge channels:** Standard with extra long legs. These are not only welded to the door skins with a resistance bridge welder, but also Seam welded with a Mig gun to provide structural support and stability the full length of the door edges.

Available edge options

- **Seamless Welded Vertical Edges (Standard) –** Edge seam includes 1” long center seam welds every 6” of the full height and then epoxy filled.
- **Continuously Welded Vertical Edges (Optional) –** Edge Seam is continuously Mig welded and finished smooth.

4. **Gasketing Combinations:** MegaSonic Model 2A may be ordered with a multiple gasket set. This includes all supplementary gaskets needed for future upgrades of STC performance or to compensate for unforeseen installation inaccuracies.

5. **Beveled Lock Edge:** Allows for tighter installation tolerances, operation and eliminates binding.

6. **MegaSonic Double Door Assembly:** To meet requirements when using the standard ANSI flush bolt for double doors, our engineers have designed a unique door that doesn’t require an automatic door bottom. MegaMet developed an innovative double gasket design (patent pending) at the top and bottom channel (illustration on next page). As an assembly this achieved and STC-50 rating (OITC 36).

7. **Factory Applied Rust Inhibiting Primer:** Painted in accordance with ANSI A250.10-1998 (R2004)

Specification Compliance

1. Door construction for MegaSonic Model 2A Full Flush Doors meet the requirements of:

- HMMA 865
- ASTM E90
- ASTM E413
- ANSI/SDI A250.10 & A250.11

2. Hardware preparations and reinforcements are in accordance with ANSI A250.6-2003. Locations are in accordance with ANSI/DHI A115 unless otherwise noted.

Fire Ratings

MegaSafe doors do meet the broadest fire rating requirements. They are listed for installations requiring compliance with both neutral pressure testing (ASTM E152 and UL-10B) and positive pressure standard (UL-10C).

SERIES	MAXIMUM OPENING SIZE		JAMB DEPTH AVAILABILITY (Profile)				STANDARD PROFILE DIMENSIONS (Variations Available)			CORNERS
	Single	Pair	STANDARD		KERF		FACE	STOP	RETURNS	STANDARD
			DOUBLE RABBET	DOUBLE RABBET	DOUBLE RABBET	DOUBLE RABBET				
			Minimum	Maximum	Minimum	Maximum				
2A-B *14ga.	5'-0" x 12'-0" (1524mm x 3658mm) ***	10'-0" x 12'-0" (3048mm x 3658mm) ***	4-1/2" (114mm)	20" (508mm)	4-3/4" (121mm)	20" (508mm)	2" (51mm)	3/4" (16mm)	1/2" (13mm)	DIE MITERED with concealed tabs interlocking head & jambs
2A-F *14ga.	5'-0" x 12'-0" (1524mm x 3658mm) ***	10'-0" x 12'-0" (3048mm x 3658mm) ***		***		***			**	

* 14 gauge is the standard material for all MegaSonic Assemblies, 12 gauge not available at kerf profile (Model 2A-F).

** except at 5 3/4" (146mm) Jamb Depth, which is 7/16" (11mm)

*** call factory for larger size availability

Frame Elevation

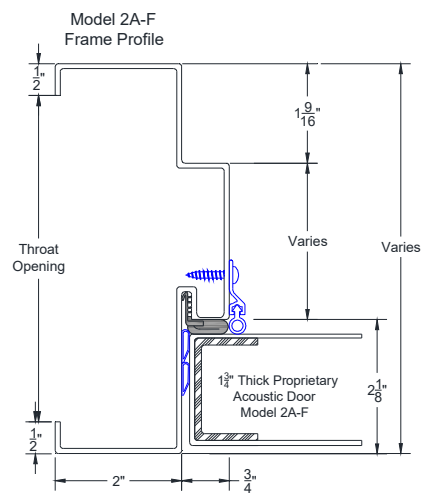
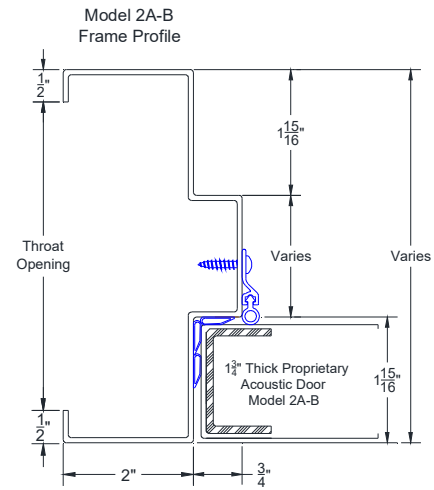
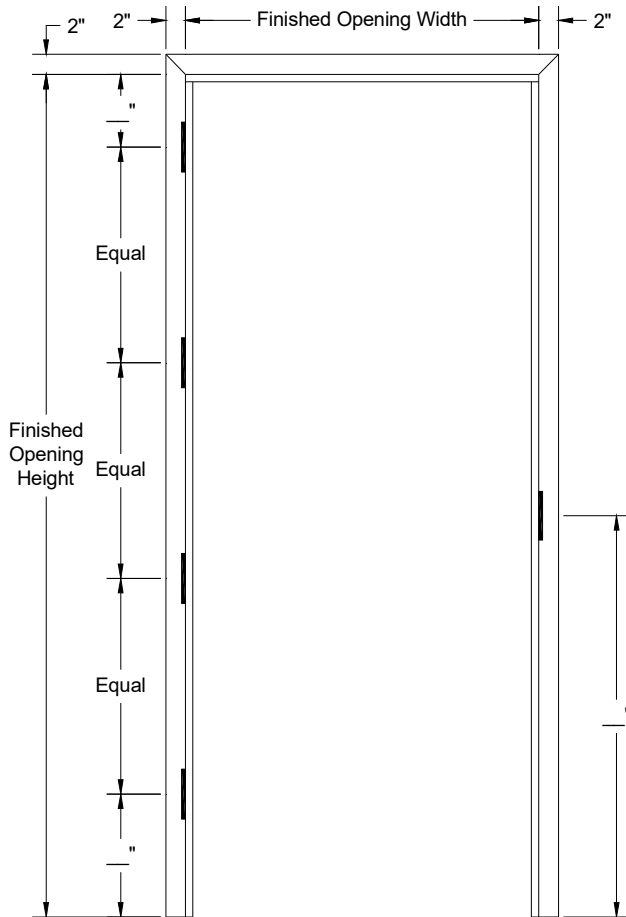

MegaSonic Door Series	STC Rating	Door Thickness	Acoustic Test & Recommendations	Fire Testing & Ratings	Building Design (Fire-Safety-Accessibility)
Model 2A-B	STC-43 through STC-48	1-3/4"	ASTM E90 ANSI S12.60 ASTM E413 DCID 6/9 (SCIF)	UL-10C NFPA 252 UL-10B NFPA 257	NFPA 80 NFPA 101 ANSI A117.1
Model 2A-F	STC-49 through STC-52	1-3/4"	ASTM E1332 SDI-128	UL Subject 63 HMMA 850	
Model 2A (Custom)	STC-53 through STC-55	2-1/4"	ASTM E1408	ASTM E152	

Patented Pending Design & Door Bottom Options

MegaSonic Model 2A double doors up to STC 50 and single doors up to STC 52 (1 3/4" thick doors) are constructed with an innovative double gasket design (patent pending) at the top and bottom channels, therefore eliminating the need for an automatic door bottom. If job conditions require it, MegaSonic Model 2A doors are optionally available with a surface mounted automatic door bottom.

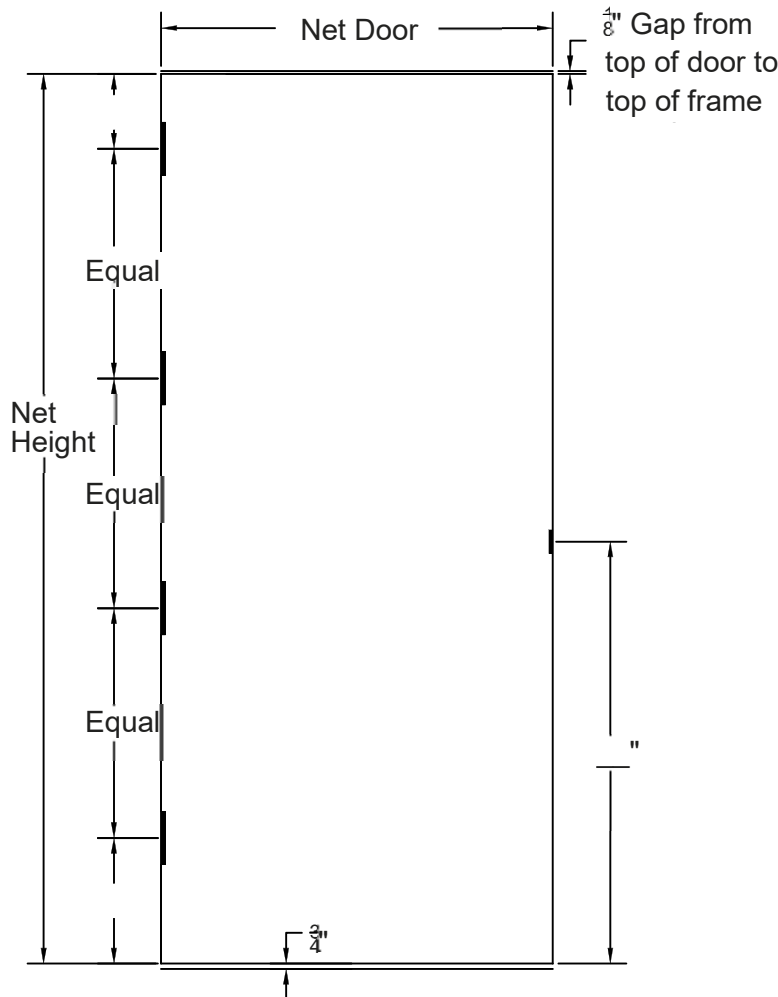
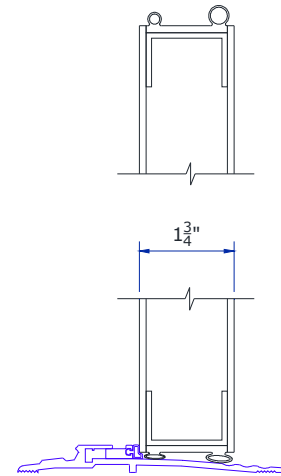
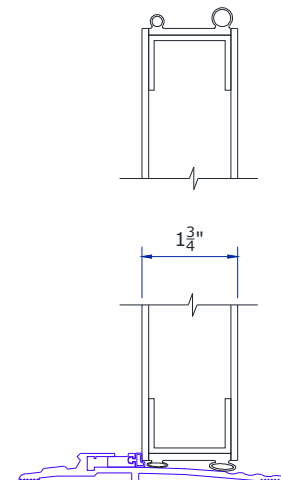
 Model 2A-B
Vertical Detail

 Model 2A-F
Vertical Detail

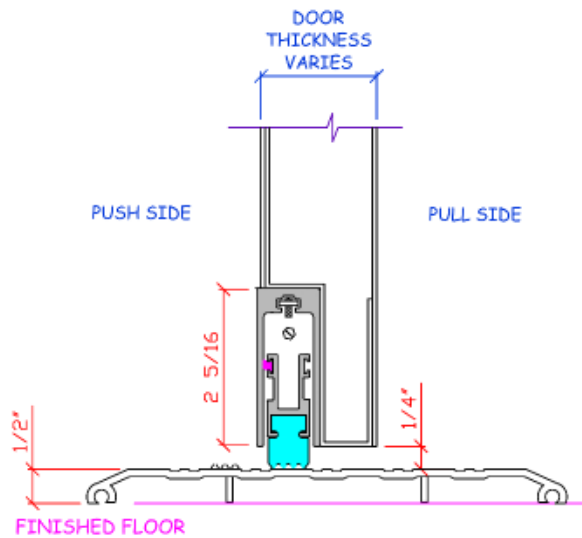
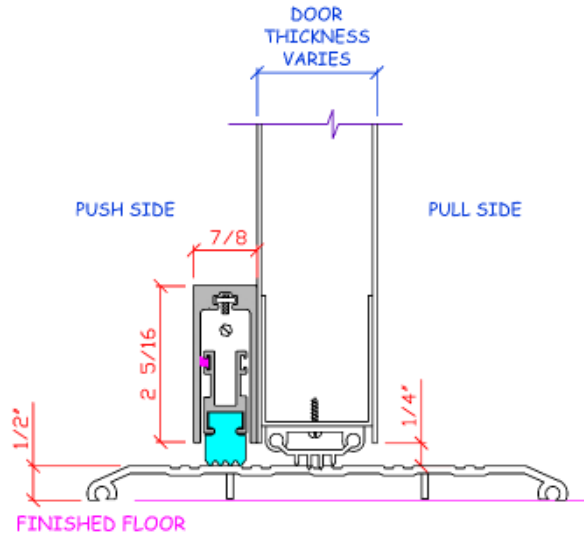
Other Door Bottom Design Options



MegaSonic Double Door Assemblies

To meet requirements allowing the use of ANSI flush bolts for double doors, our engineers designed a unique door without an automatic door bottom. MegaMet developed an innovative double gasket design (patent pending) at the top and bottom channel (see illustration at previous page) along with a low profile rabbeted meeting edge (shown below). Laboratory test for this pair, with our kerfed frame design (see illustration on previous page), as an assembly achieved an STC rating of 50 (OITC 36).

Double Door Meeting Edges With ANSI Flush Bolts

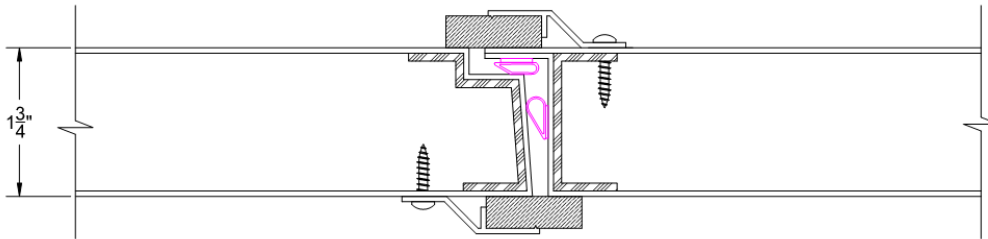

MegaSonic double door design (shown below) allows the use of exit devices such as rim exit, surface vertical rod exit devices, along others devices that are surface mounted (concealed vertical rods not allowed). This assembly, as well as the overlapping design shown above, has achieved an STC rating of 50 (OITC 36).

Double Door Meeting Edges With Exit Device

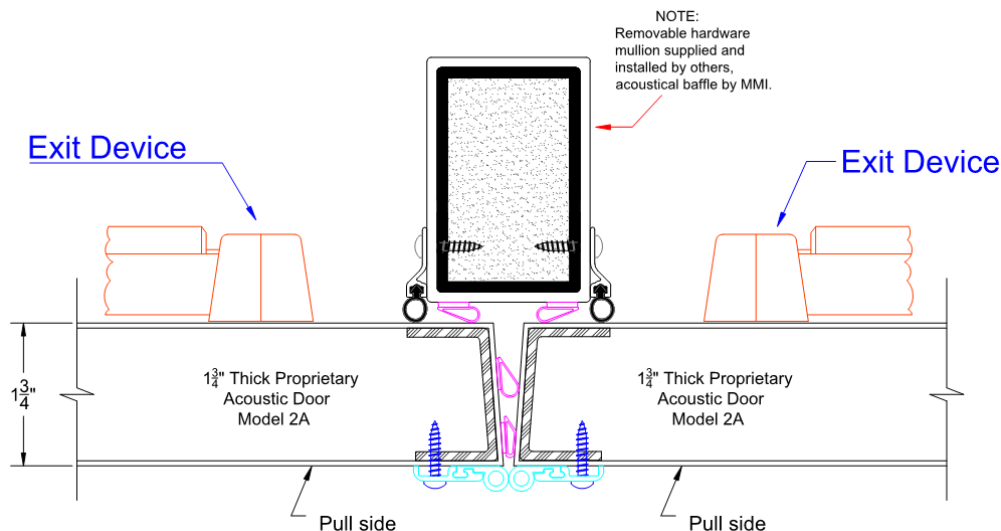

MegaSonic door assemblies also offer a higher STC rating on both configurations single or double door openings. With MegaMet's MegaSonic Model 2A standardized design and component system we can produce a 2", 2 1/4" or thicker doors with an additional acoustic barrier layer to meet your needs. So if your project requires a higher STC rating please feel free to contact the factory with your specifications for further details and availability.

Glazing in Doors

Doors prepped for glazing do not react the same as flush doors in acoustic test. The light kit design, attachment, type and combination of glass or glazing, and the glazing putty, tape or channels interrupt the door's acoustic core and therefore the performance. The STC (or STL) of a flush door may be reduced by anywhere from 5 to 15 when glazing is incorporated. As an example, the use of glazing system available from a major manufacturer is rated at STC 44 when tested with non-operable panel tested at STC 55. STC ratings of glazed 1 3/4" doors from other manufacturers are STC rated in the low to mid 40s.

MegaMet lite kits are manufactured with State-of-Art designs that minimize sound transmission, yet still have the "good looks" you would expect from MegaMet! Our 1 3/4" MegaSonic door designs will reduce the inherent negative effect of glazing.

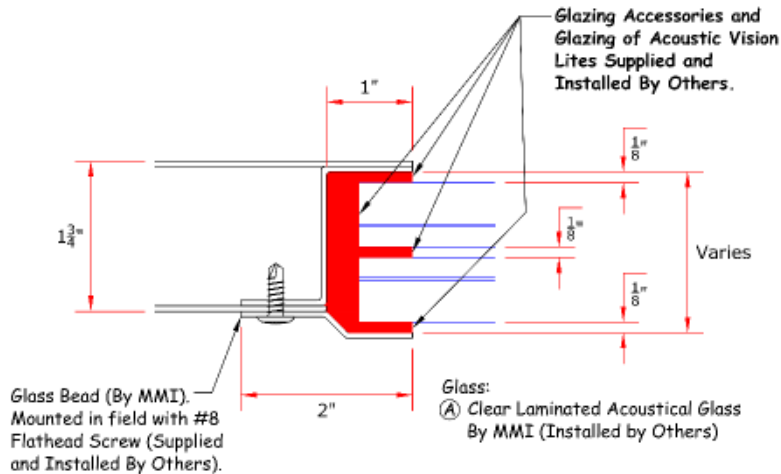

Our Product Must be Installed in Accordance with Proper Glazing Techniques as Set Forth in the Glass Association of North America (GANA) Glazing Manual and Sealant Manual 1990 (Or Most Current Edition).

Project Designs Requiring Wood Veneer and Plastic Laminates

If the design elements of the project require wood veneer, MegaMet can readily provide it for you. Exotic species from anegre to zebrawood can be expertly applied. The more common veneers of rotary natural birch and plain sliced red oak are always available for your project needs.

Standard veneer lay-ups:

- Running Match
- Book Matched
- Balanced Matched
- Random Match

Any solid or patterned plastic laminate can be applied at MegaMet's facility on all standard or speciality doors.

